

SWINGAWAY ALIGNMENT ASSEMBLY

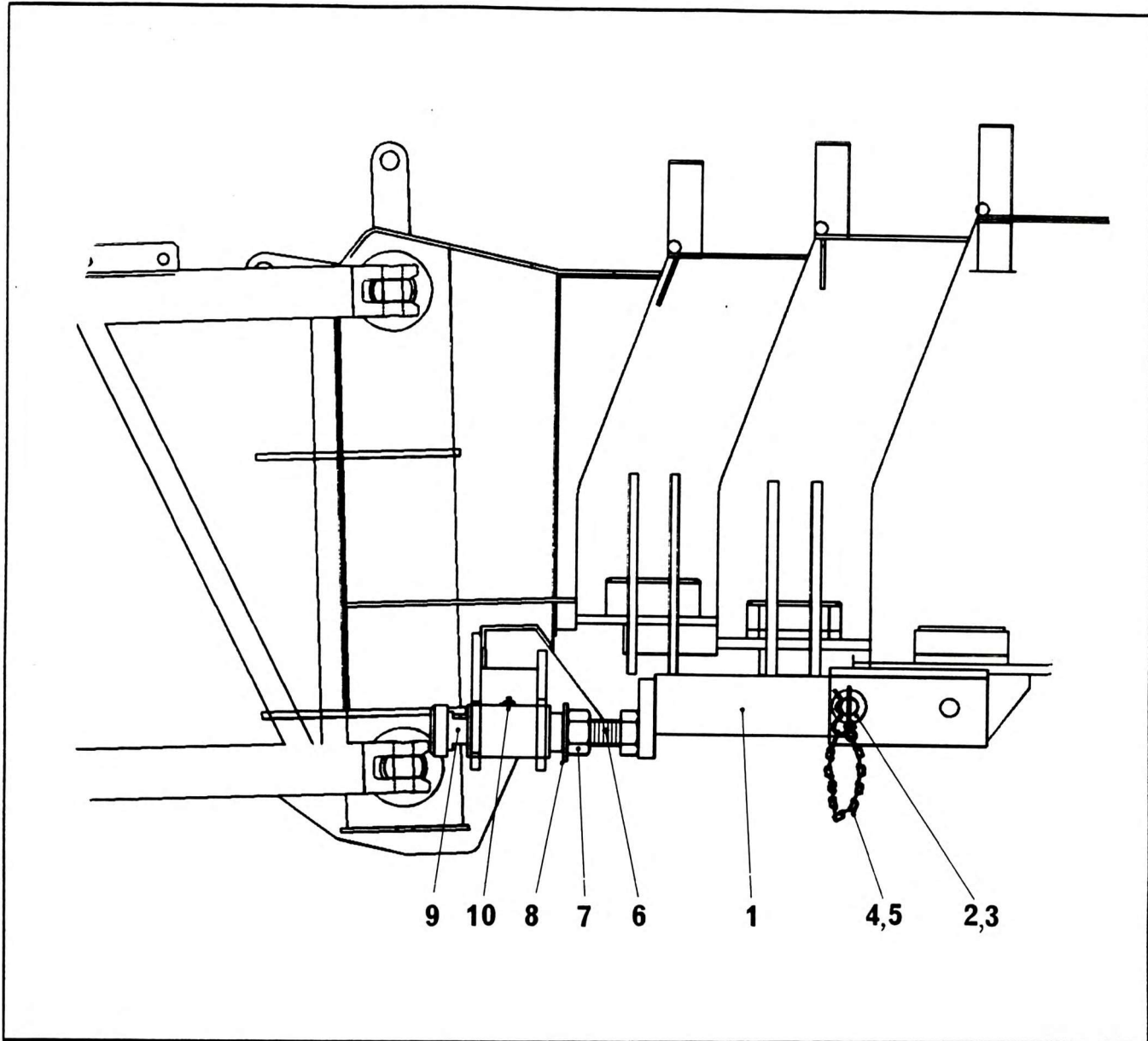

NO.	PART NO.	QTY.	DESCRIPTION	NO.	PART NO.	QTY.	DESCRIPTION
1	6-966-990383	1	Push Bar Weld				
2	7-689-000721	1	Pin Lock Hitch Pin				
3	7-689-000036	1	Clip Pin				
4	7-601-000253	2	Open End Link				
5	6-286-000012	1	Coil Chain				
6	7-118-344050	1	1½" UNC x 5" Cap Screw				
7	7-660-340200	1	1½" UNC Jam Nut				
8	7-950-340141	1	1½" Flat Washer				
9	6-059-990212	1	Pusher Bar				
10	7-440-000000	1	Grease Fitting				